

APPROVAL SHEET

(RoHS)

CUSTOMER : _____

CUSTOMER'S PART NO. : _____

DESCRIPTION : Multi-layer Balance Filter

PART NO. : BBF-2012-2G4H6-A1

DATE : _____

AUTHORIZED BY : Yunwei Lin

| | FULLY APPROVED | PARTIALLY APPROVED | REJECTED |
|------------|----------------|--------------------|----------|
| SIGN | | | |
| SUGGESTION | | | |

美磊科技股份有限公司

MAG. LAYERS SCIENTIFIC-TECHNICS CO., LTD
HEAD OFFICE / HSINCHU PLANT

No 18, Tz-Chiang Road, Hsin-Chu Industrial Park, Hsin-Chu, Taiwan

TEL: +886-3-5972488 FAX: +886-3-5972477

<http://www.maglayers.com.tw>

E-mail : info@maglayers.com.tw



MAG.LAYERS

APPLICATION

2.4GHz WLAN, Home RF, Bluetooth Modules, etc.

FEATURES

- Compact Size**
Miniaturized SMD packaged in low profile and lightweight.
- Low Loss**
Low insertion loss, high attenuation.
- High Soldering Heat Resistance**
High quality termination allows both flow and re-flow soldering methods to be applied.
- Characteristics**
Eliminates noise over a wide frequency range. Idea for high frequency and space limited designs
- Internal Shielding incorporated**
- Available in tape and reel packaging for automatic mounting**

PRODUCT IDENTIFICATION

BBF - 2012 - ###XX - A1
① ② ③ ④

- ① Product Code
- ② Dimension Code
- ③ Series Type (### represents center frequency and XX represents material type)
- ④ Design Code

ELECTRICAL REQUIREMENTS

| Part NO. | Pass Band | Insertion Loss | Ripple | VSWR | Phase Differential | Amplitude Balance | Attenuation |
|-------------------|------------|----------------|-------------|----------|--------------------|-------------------|---|
| BBF-2012-2G4H6-A1 | 2450±50MHz | 3.5 dB Max. | 1.0 dB Max. | 2.0 Max. | 180±10 deg. | 1.0 dB Max. | 45dB min. at 880~960MHz 35dB min. at 1710~1880MHz 28dB min. at 1880~1990MHz 25dB min. at 4800~5000MHz 20dB min. at 7200~7500MHz |

Unbalance impedance : 50 ohm

Balance impedance : Conjugate match to CSR BC series.



PRODUCT DIMENSIONS

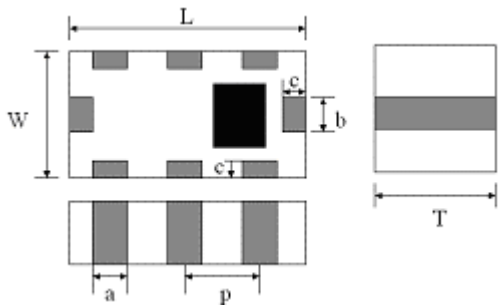

| L | W | T | a |
|--------------------|-----------|-----------|--------------------|
| 2.0±0.20 | 1.25±0.20 | 1.0±0.10 | 0.30+0.10 -0.15 |
| b | c | p | |
| 0.30+0.10 -0.15 | 0.20±0.15 | 0.65±0.15 | |

NOTE : Dimensions in mm

TERMINAL CONFIGURATION

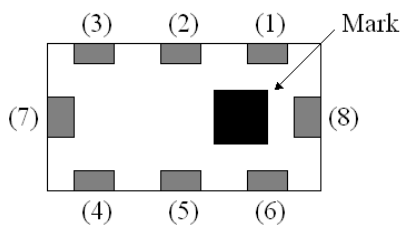

- (1) : Unbalance Port
- (2) : DC
- (3) : NC
- (4) : Balance Port
- (5) : GND
- (6) : Balance Port
- (7) : GND
- (8) : GND

MEASURING DIAGRAM

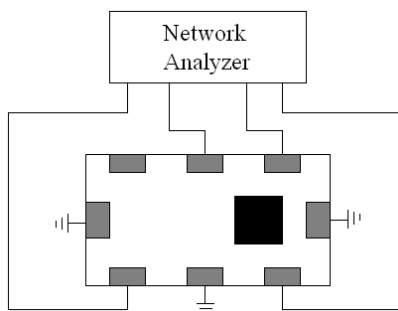

Test Instrument:
Agilent E5071A Network Analyzer

RECOMMENDED PCB LAYOUT

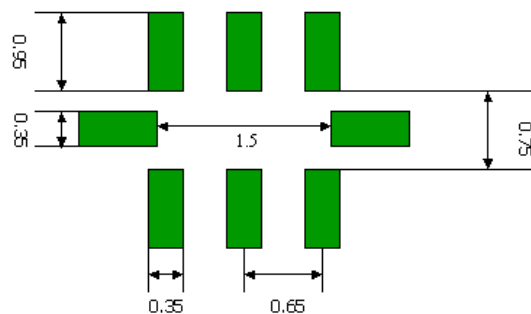

: Soldering Pad

Unit: mm

ELECTRICAL CHARACTERISTICS (T=25°C)

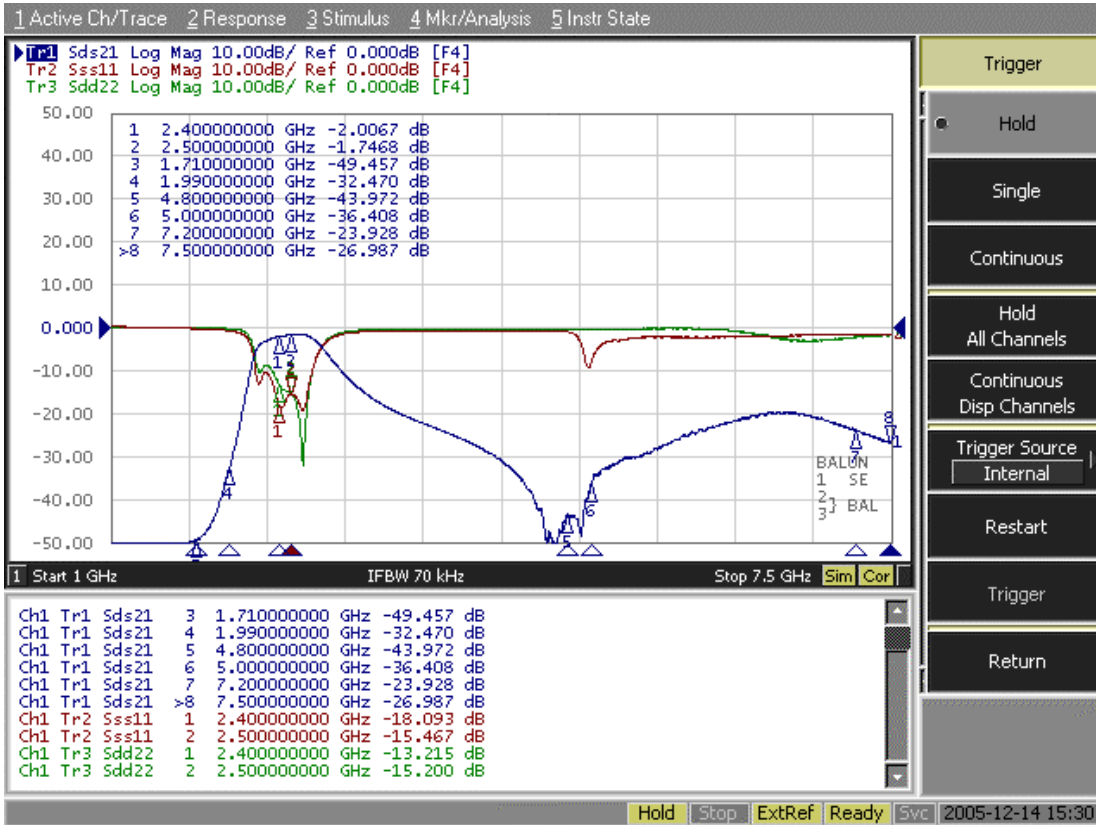

Return Loss (Unbalance)

Return Loss (Balance)

Insertion Loss

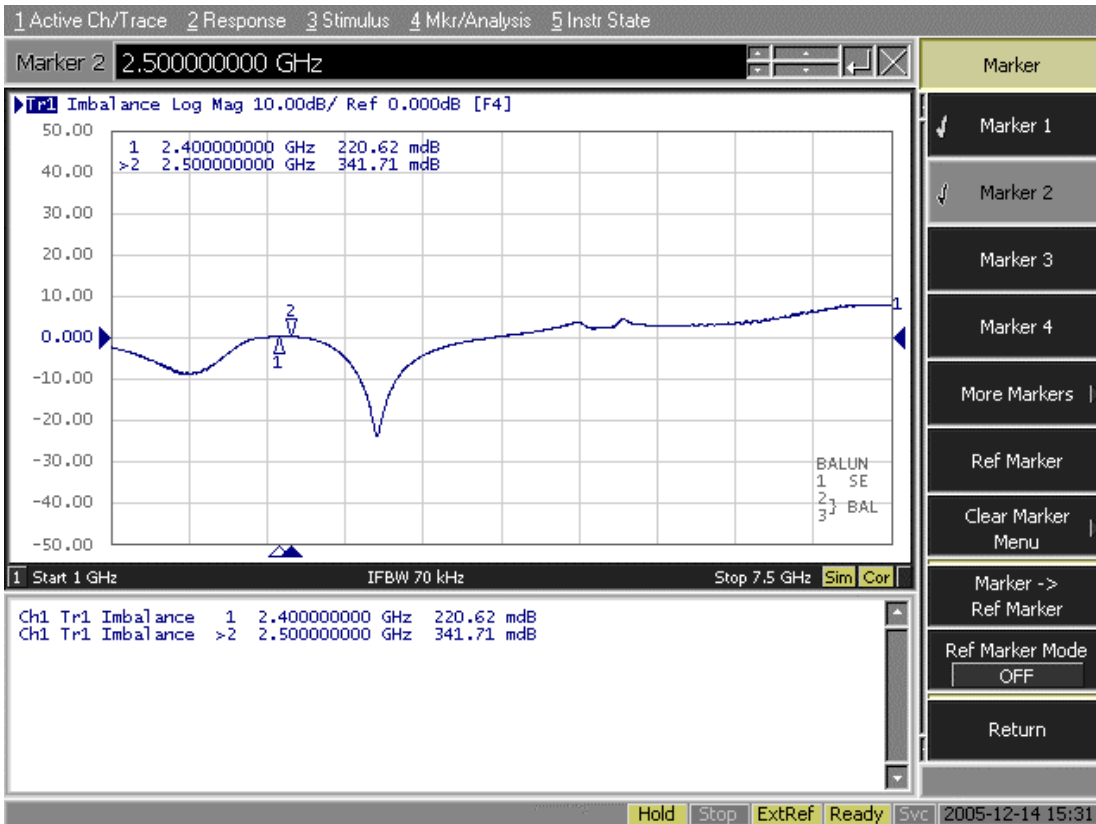

Amplitude Imbalance

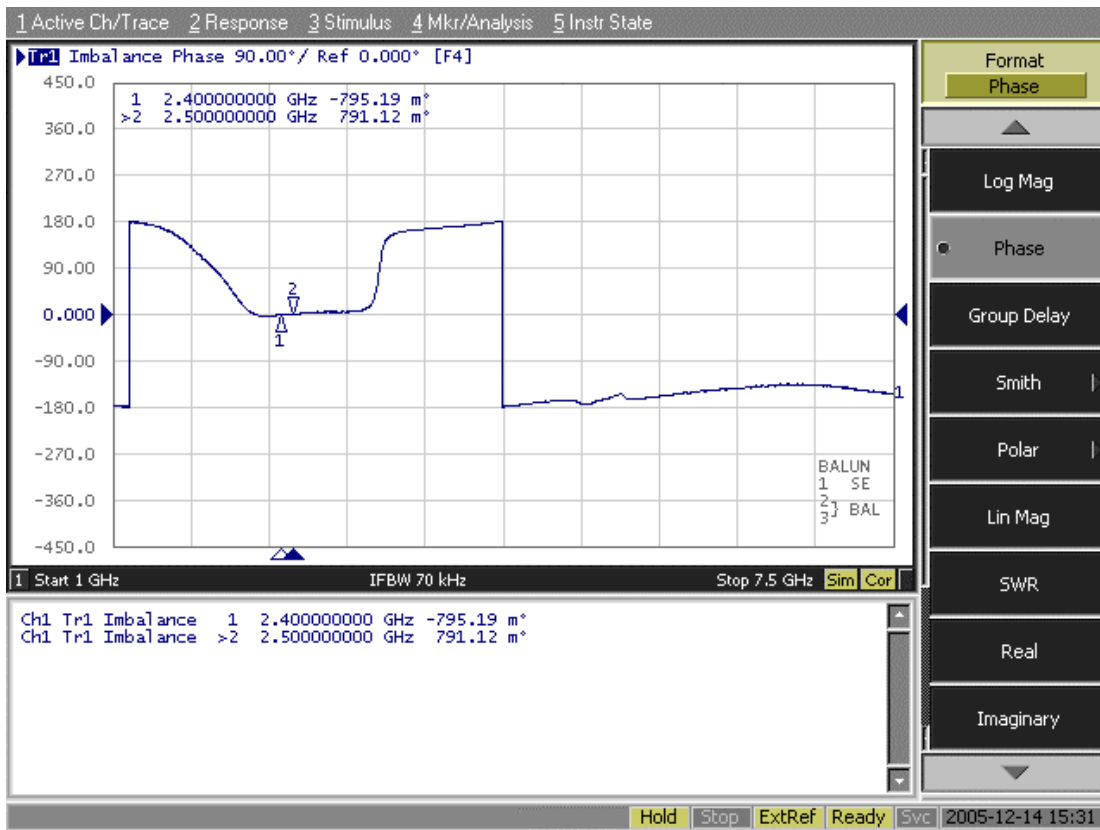

Phase Imbalance

PACKAGING FOR SMC

Peel-off force

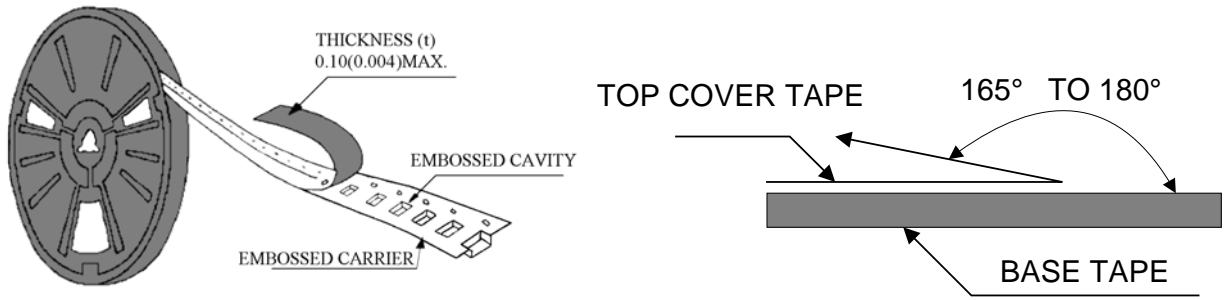

The force for peeling off cover tape is 10 grams in the arrow direction.

Dimension (Unit: mm)

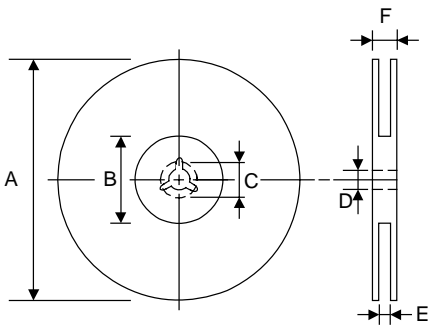

| TYPE | A | B | C | D | E | F |
|-------|---------|---------------|-----------|-----------|-----------|---------|
| 8 mm | 178±1 | 60 +0.5 -0 | - | 13 ±0.2 | 9 ±0.5 | 12 ±0.5 |
| 12 mm | 178±0.3 | 60 ±0.2 | 19.3 ±0.1 | 13.5 ±0.1 | 13.6 ±0.1 | - |

Taping quantity

| SERIES | 5824 | 5220 5320 | 4532 | 4516 | 3225 | 3216 2520 | 2012 1608 | 1005 |
|----------|------|--------------|------|------|------|--------------|--------------|-------|
| PCS/Reel | 5000 | 3000 | 1000 | 2000 | 2500 | 3000 | 4000 | 10000 |

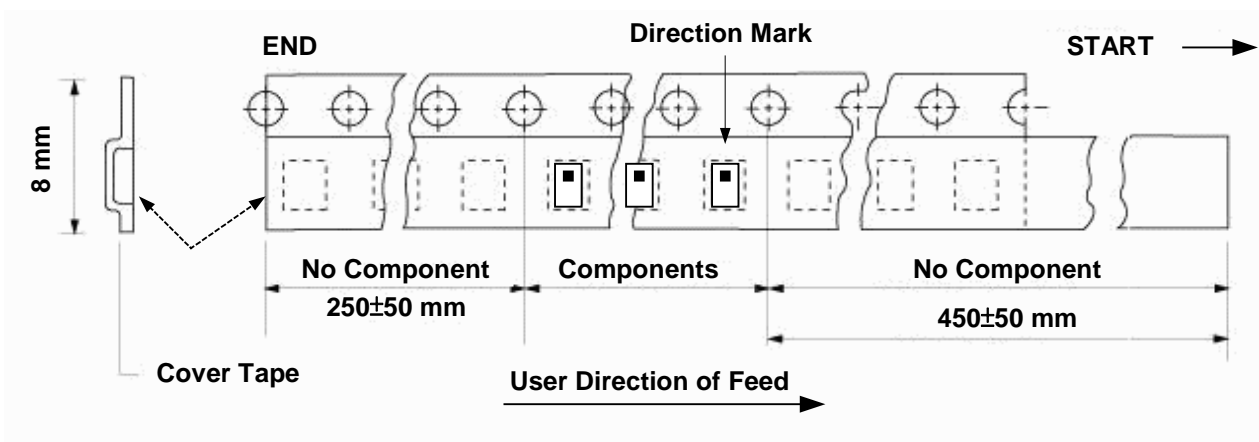

TAPE PACKING CASE

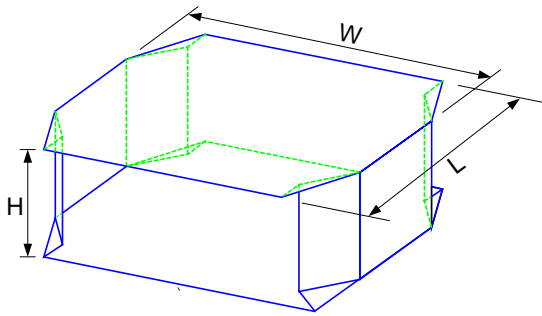

Unit:cm

| No. of Reels | W | L | H |
|--------------|--------|--------|---------|
| 2 | 18±0.5 | 18±0.5 | 2.4±0.2 |
| 3 | 18±0.5 | 18±0.5 | 3.6±0.2 |
| 4 | 18±0.5 | 18±0.5 | 4.8±0.2 |
| 5 | 18±0.5 | 18±0.5 | 6.0±0.2 |

ATTENTION REGARDING PCB BENDING

- (a) PCB shall be designed so that products are not subjected to the mechanical stress for board warpage. Product shall be located in the sideway direction to the mechanical stress.

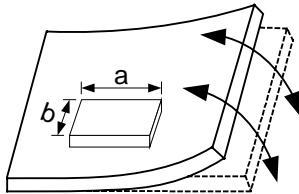

(Poor example)

Length: $a > b$

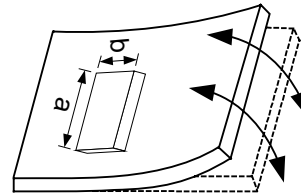

(Good example)

- (b) Products (A,B,C,D) shall be located carefully so that products are not subjected to the mechanical stress due to warping the board. Because they may be subjected to the mechanical stress in order of $A > C > B \approx D$.

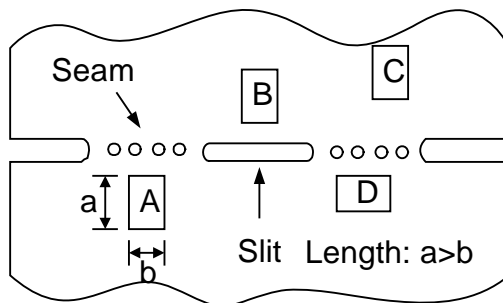

RELIABILITY TEST

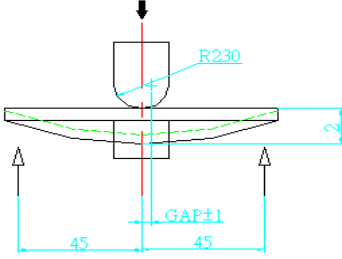
| Item | Condition | Specification |
|--|---|---|
| Thermal shock | -40°C~+85°C for 100 cycles each cycle being 30 min | No apparent damage Fulfill the electrical spec. after test |
| Humidity resistance | 85±2°C, 80~90% R.H. for 500 hours | No apparent damage Fulfill the electrical spec. after test |
| High temperature resistance | +85±2°C for 500 hours | No apparent damage Fulfill the electrical spec. after test |
| Low temperature resistance | -40±3°C for 500 hours | No apparent damage Fulfill the electrical spec. after test |
| Vibration | 10 Hz/min~55 Hz/min~10 Hz/min vibration frequency with 1.5 mm amplitude for two hours in x, y, z directions | No apparent damage |
| Drop shock | Dropped onto printed circuit board from 100cm height three times in x, y, z directions. The terminals shall be protected. | No apparent damage |
| Soldering heat resistance | Preheating temperature : 150±10°C Preheating time : 1 to 2 minutes Solder bath temperature : 260±5°C Bathing time : 5±0.5 seconds | No apparent damage |
| Bending test onto printed circuit board | <p>Solder specimen LTCC components on the test printed circuit board (L: 100 x W: 40 x T: 1.6mm) in appended recommended PCB pattern.</p> <p>Apply the load in direction of the arrow until bending reaches 2 mm.</p>  <p>Unit: mm</p> | No apparent damage |
| Solderability | The dipped surface of the terminal shall be at least 75% covered with solder after dipped in solder bath of 235±5°C for 3±0.5 seconds. | No apparent damage |

STORAGE CONDITION

The temperature should be within 0 ~ 30°C and humidity should be less than 75% RH. The product should be used within 6 months from the time of delivery.

RECOMMENDED REFLOW SOLDERING PROFILE

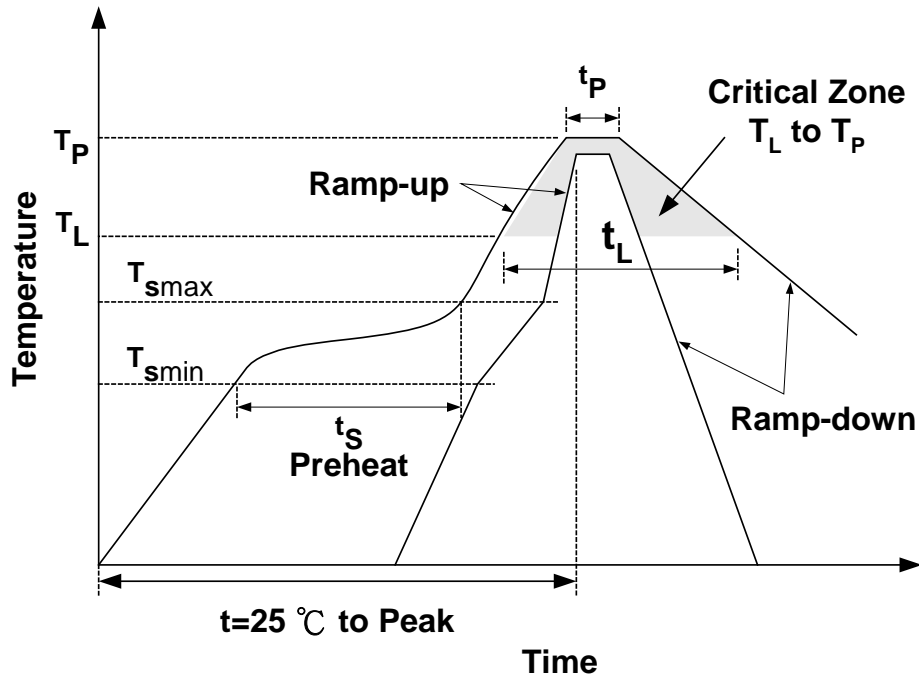

| Profile Feature | | Sn-Pb | Pb-Free |
|--|-----------------------|-----------------|-----------------|
| Preheat | t_s | 60~120 seconds | 60~180 seconds |
| | T_{smin} | 100°C | 150°C |
| | T_{smax} | 150°C | 200°C |
| Average ramp-up rate (T_{smax} to T_P) | | 3°C/second max. | 3°C/second max. |
| Time main above | Temperature (T_L) | 183°C | 217°C |
| | Time (t_L) | 60~150 seconds | 60~150 seconds |
| Peak temperature (T_P) | | 230°C | 250~255°C |
| Time within 5°C of actual peak temperature (t_p) | | 10 seconds | 10 seconds |
| Ramp-down rate | | 6°C/sec max. | 6°C/sec max. |
| Time 25°C to peak temperature | | 6 minutes max. | 8 minutes max. |

NOTES

The contents of this data sheet are subject to change without notice. Please confirm the specifications and delivery conditions when placing your order.