

APPROVAL SHEET

(RoHS)

CUSTOMER : _____

CUSTOMER'S PART NO. : _____

DESCRIPTION : Multi-layer Chip Diplexer for 802.11 a/b/g

PART NO. : LTD-2012-2G4S1-A1

DATE : _____

AUTHORIZED BY : *Yunwei Lin*

	FULLY APPROVED	PARTIALLY APPROVED	REJECTED
SIGN			
SUGGESTION			

美磊科技股份有限公司

MAG. LAYERS SCIENTIFIC-TECHNICS CO., LTD
HEAD OFFICE / HSINCHU PLANT

No 18, Tz-Chiang Road, Hsin-Chu Industrial Park, Hsin-Chu, Taiwan

TEL: +886-3-5972488 FAX: +886-3-5972477

<http://www.maglayers.com.tw>

E-mail : info@maglayers.com.tw

APPLICATION

Dual-band WLAN.

FEATURES

- **Compact Size**
Miniaturized SMD packaged in low profile and lightweight.
- **Low loss**
Low insertion loss, high attenuation.
- **High Soldering Heat Resistance**
High quality termination allows both flow and re-flow soldering methods to be applied.
- **Characteristics**
Eliminates noise over a wide frequency range. Idea for high frequency and space limited designs.
- **Internal Shielding incorporated**
- **Available in tape and reel packaging for automatic mounting**

PRODUCT IDENTIFICATION

L T D - 2 0 1 2 - ### x x - A 1
① ② ③ ④

- ① Product Code
- ② Dimension Code
- ③ Series Type (### represents center frequency and xx represents material type)
- ④ Design Code

ELECTRICAL REQUIREMENTS

Part NO.	Item	Frequency Range	Insertion Loss	VSWR	Stop-Band Attenuation
LTD-2012-2G4S1-A1	Common to Low Freq. Port	2400~2500 MHz	0.7 dB max.	2.0 max.	20 dB min. at 4800~6000 MHz
					20 dB min. at 7200~7500 MHz
	Common to High Freq. Port	4900~5950 MHz	1.3 dB max.	2.0 max.	25 dB min. at 1800~2500 MHz
					25 dB min. at 9800~11900 MHz
Common Port	2400~2500 MHz	-	2.0 max.		

PRODUCT DIMENSION

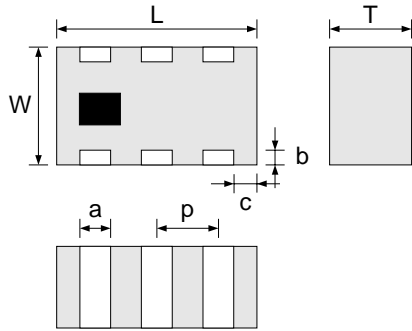

L	W	T	a
2.00±0.15	1.25±0.15	0.95±0.10	0.30 +0.10/ -0.15
b	c	p	
0.30 +0.10/ -0.20	0.20±0.20	0.65±0.20	

NOTE : Dimensions in mm

TERMINAL CONFIGURATION

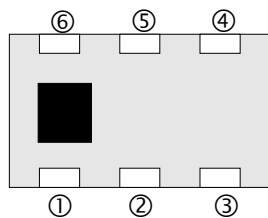

- ① Low Frequency Port
- ③ High Frequency Port
- ⑤ Common Port
- ②④⑥ GND

MEASURING DIAGRAM

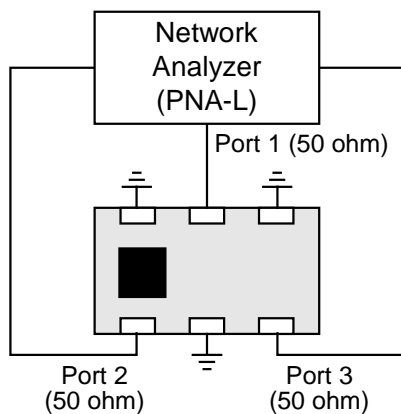

Test Instrument:
Agilent N5230A Network Analyzer

RECOMMENDED PCB LAYOUT

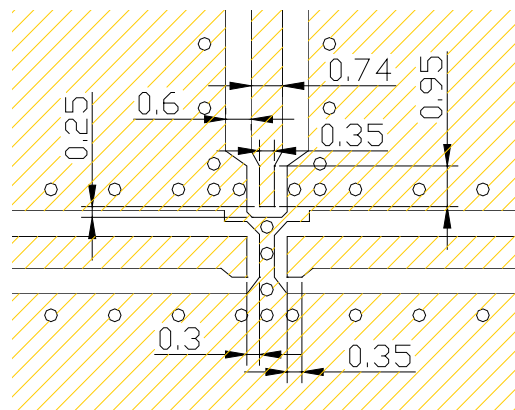

ELECTRICAL CHARACTERISTICS (T=25°C)

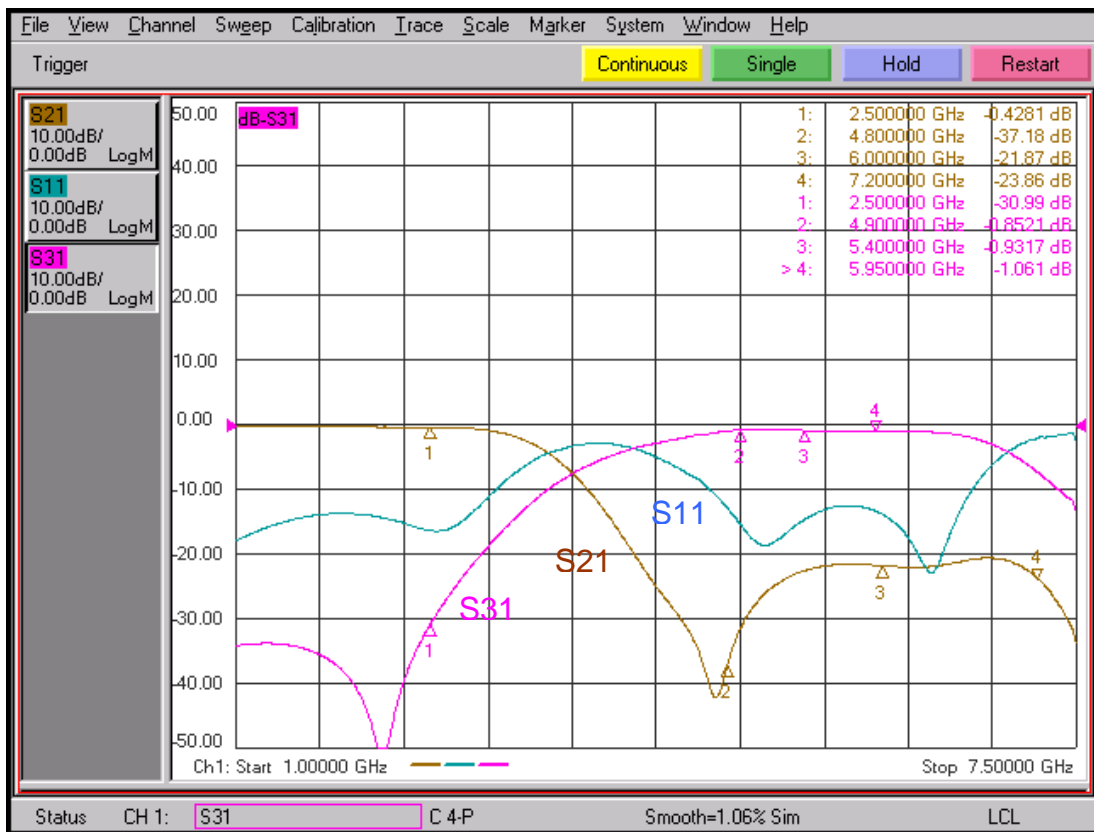

PACKAGING FOR SMC

Peel-off force

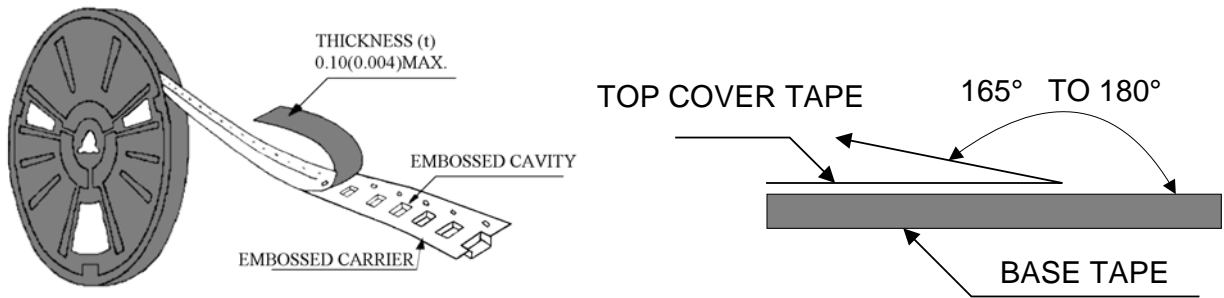

The force for peeling off cover tape is 10 grams in the arrow direction.

Dimension (Unit: mm)

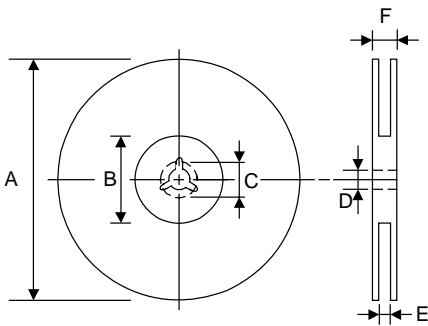

TYPE	A	B	C	D	E	F
8 mm	178±1	60 +0.5 -0	-	13 ±0.2	9 ±0.5	12 ±0.5
12 mm	178±0.3	60 ±0.2	19.3 ±0.1	13.5 ±0.1	13.6 ±0.1	-

Taping quantity

SERIES	5824	5320 5220	4532	4516	3225	3216 2520	2012 1608	1005
PCS/Reel	5000	3000	1000	2000	2500	3000	4000	10000

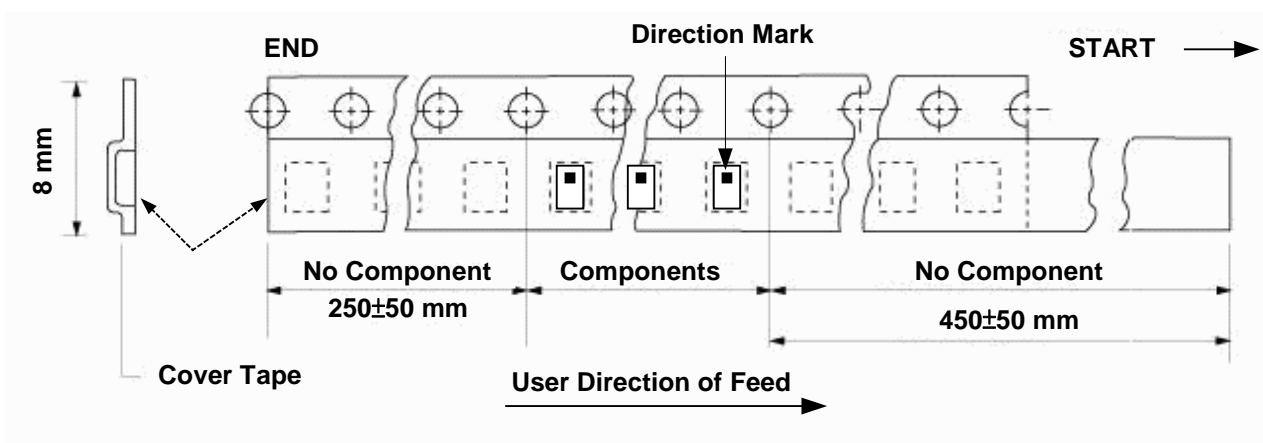

TAPE PACKING CASE

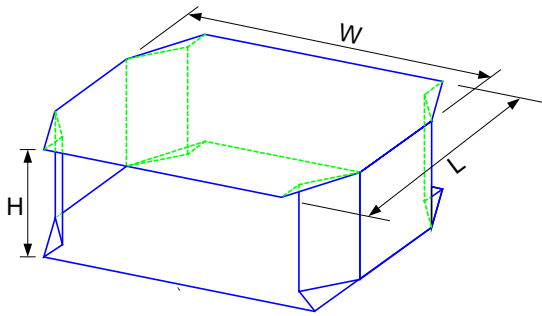

Unit:cm

No. of Reels	W	L	H
2	18±0.5	18±0.5	2.4±0.2
3	18±0.5	18±0.5	3.6±0.2
4	18±0.5	18±0.5	4.8±0.2
5	18±0.5	18±0.5	6.0±0.2

ATTENTION REGARDING PCB BENDING

- (a) PCB shall be designed so that products are not subjected to the mechanical stress for board warpage. Product shall be located in the sideways direction to the mechanical stress.

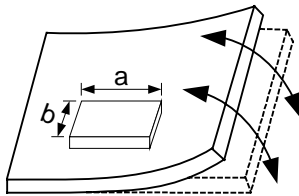

(Poor example)

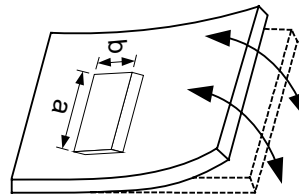

(Good example)

- (b) Products (A,B,C,D) shall be located carefully so that products are not subjected to the mechanical stress due to warping the board. Because they may be subjected to the mechanical stress in order of $A > C > B \approx D$.

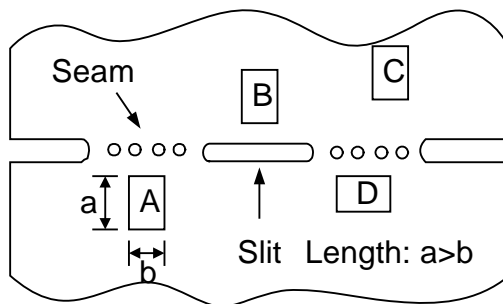

RELIABILITY TEST

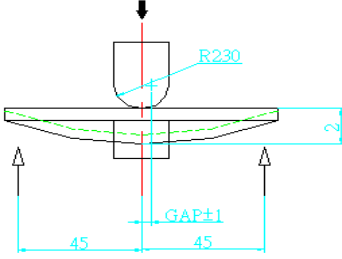
Item	Condition	Specification
Thermal shock	-40°C~+85°C for 100 cycles each cycle being 30 min	No apparent damage Fulfill the electrical spec. after test
Humidity resistance	85±2°C, 80~90% R.H. for 500 hours	No apparent damage Fulfill the electrical spec. after test
High temperature resistance	+85±2°C for 500 hours	No apparent damage Fulfill the electrical spec. after test
Low temperature resistance	-40±3°C for 500 hours	No apparent damage Fulfill the electrical spec. after test
Vibration	10 Hz/min~55 Hz/min~10 Hz/min vibration frequency with 1.5 mm amplitude for two hours in x, y, z directions	No apparent damage
Drop shock	Dropped onto printed circuit board from 100cm height three times in x, y, z directions. The terminals shall be protected.	No apparent damage
Soldering heat resistance	Preheating temperature : 150±10°C Preheating time : 1 to 2 minutes Solder bath temperature : 260±5°C Bathing time : 5±0.5 seconds	No apparent damage
Bending test onto printed circuit board	<p>Solder specimen LTCC components on the test printed circuit board (L: 100 x W: 40 x T: 1.6mm) in appended recommended PCB pattern.</p> <p>Apply the load in direction of the arrow until bending reaches 2 mm.</p>  <p>Unit: mm</p>	No apparent damage
Solderability	The dipped surface of the terminal shall be at least 75% covered with solder after dipped in solder bath of 235±5°C for 3±0.5 seconds.	No apparent damage

STORAGE CONDITION

The temperature should be within 0 ~ 30°C and humidity should be less than 75% RH. The product should be used within 6 months from the time of delivery.

RECOMMENDED REFLOW SOLDERING PROFILE

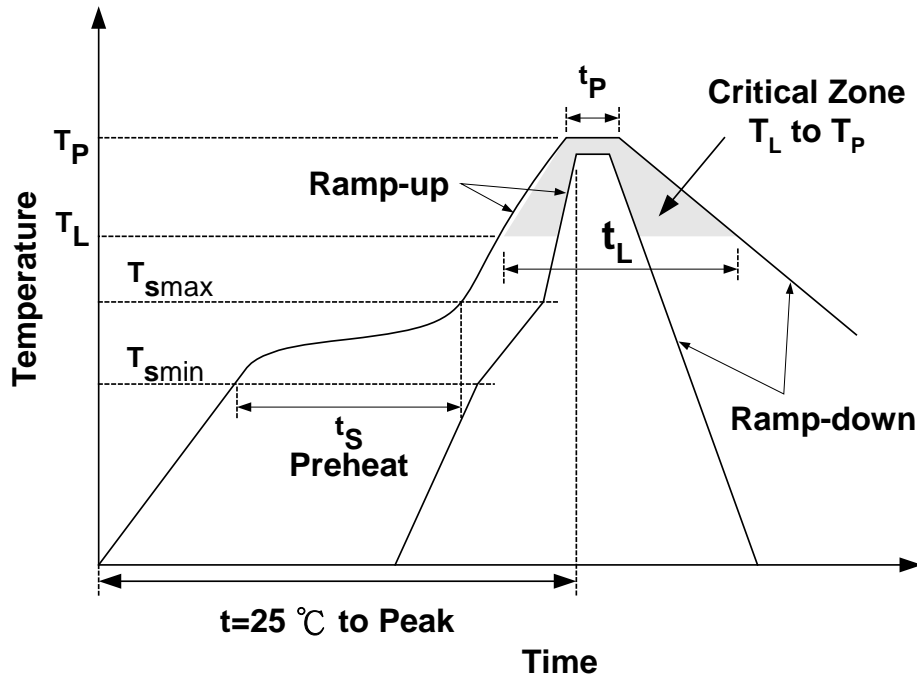

Profile Feature		Sn-Pb	Pb-Free
Preheat	ts	60~120 seconds	60~180 seconds
	Tsmin	100°C	150°C
	Tsmax	150°C	200°C
Average ramp-up rate (Tsmax to Tp)		3°C/second max.	3°C/second max.
Time main above	Temperature (TL)	183°C	217°C
	Time (tL)	60~150 seconds	60~150 seconds
Peak temperature (Tp)		230°C	250~255°C
Time within 5°C of actual peak temperature (tp)		10 seconds	10 seconds
Ramp-down rate		6°C/sec max.	6°C/sec max.
Time 25°C to peak temperature		6 minutes max.	8 minutes max.

NOTES

The contents of this data sheet are subject to change without notice. Please confirm the specifications and delivery conditions when placing your order.