

# **ANTENNA APPLICATION NOTE FOR DBA-7040-25GS3-A1**

# INSTALLATION GUIDELINE

# ANTENNA INSTALLATION GUIDELINE

- I. Follow the recommended layout proposal will minimize the effort for the post antenna fine tuning**
- II. Any component or device is not allowed to be placed in the ground clearance area**
- III. Thicker PCB will results in operational bands of antenna drift to lower side.**
- IV. Housing material with thicker thickness, higher dielectric constant and closer distance to the antenna will also results in operational bands of antenna drift to lower side.**

# RECOMMENDED ANTENNA ARRANGEMENT



Horizontal Installation

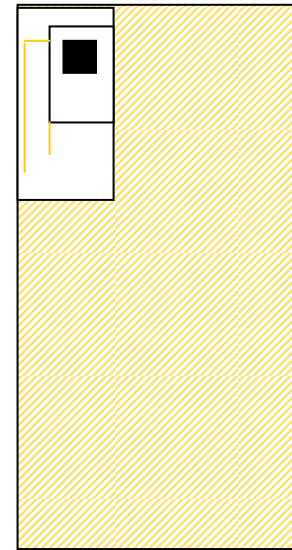

Vertical Installation

# APPLICATION EXAMPLES

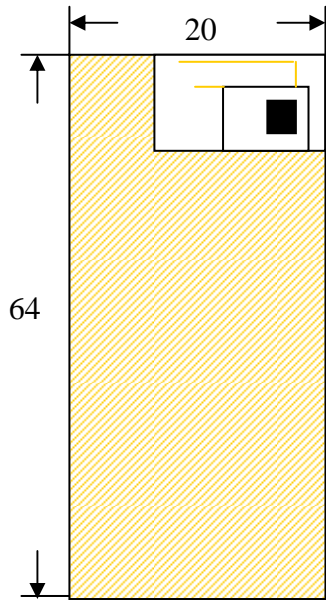

Small Card  
(USB Dongle)

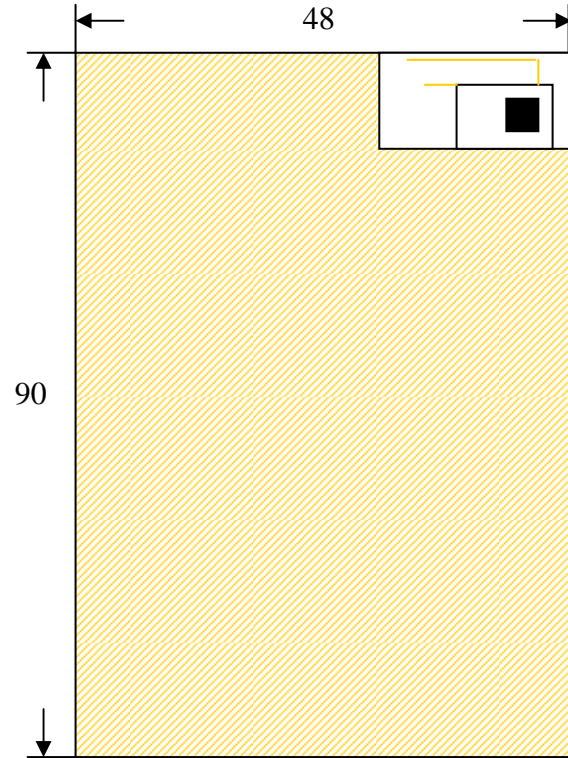

Larger Card  
(Cardbus)

Unit : mm

# RECOMMENDED PCB LAYOUT FOR SMALL CARD

Top Side

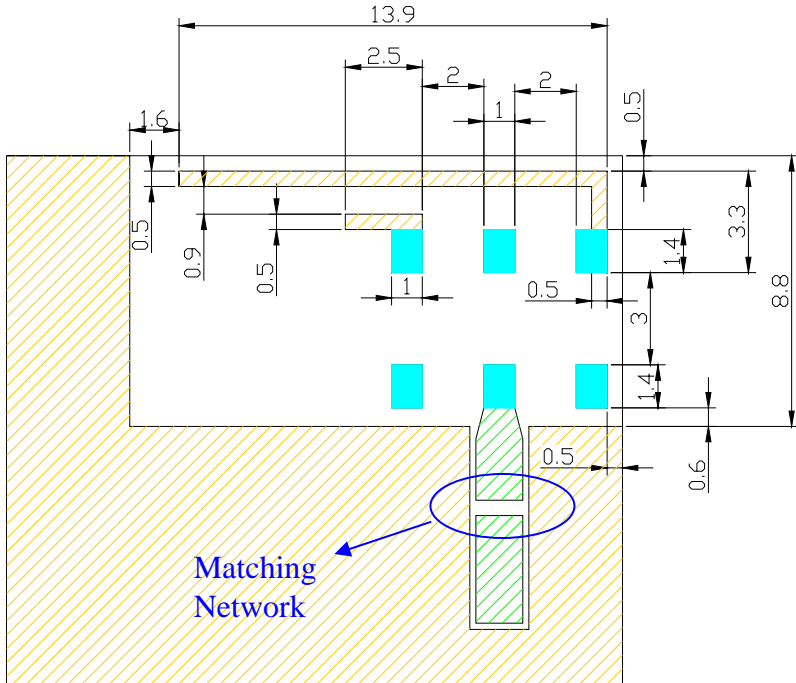

Bottom Side

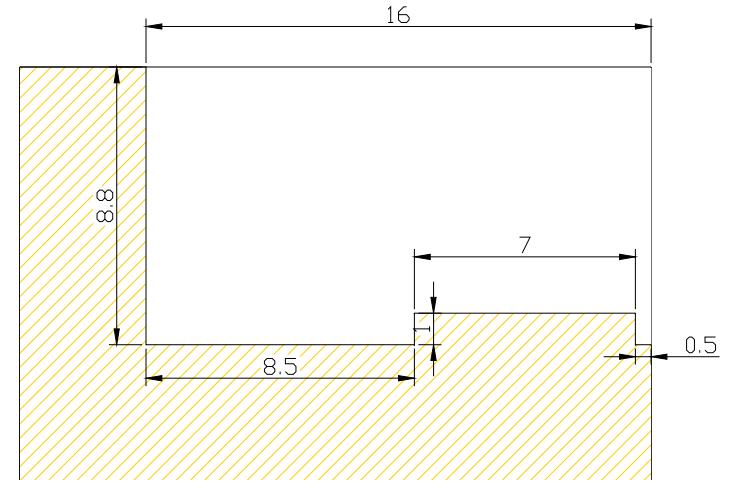

-  50 ohm Feed Line
-  Land
-  Ground

Unit : mm

\* The  $\Pi$ -type matching network should be reserved and placed as close as antenna feeding point.



# TYPICAL FREQUENCY RESPONSE FOR DIFFERENT ANTENNA INSTALLAION – SMALL CARD (VERTICAL)

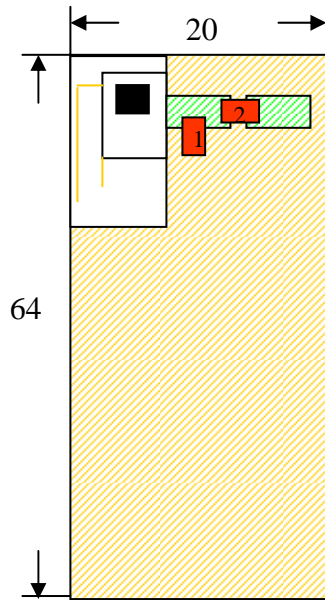

 50 ohm Feed Line

 Matching Component

1 → 3.3 nH inductor shunt to ground

2 → 0 ohm bypass resistor

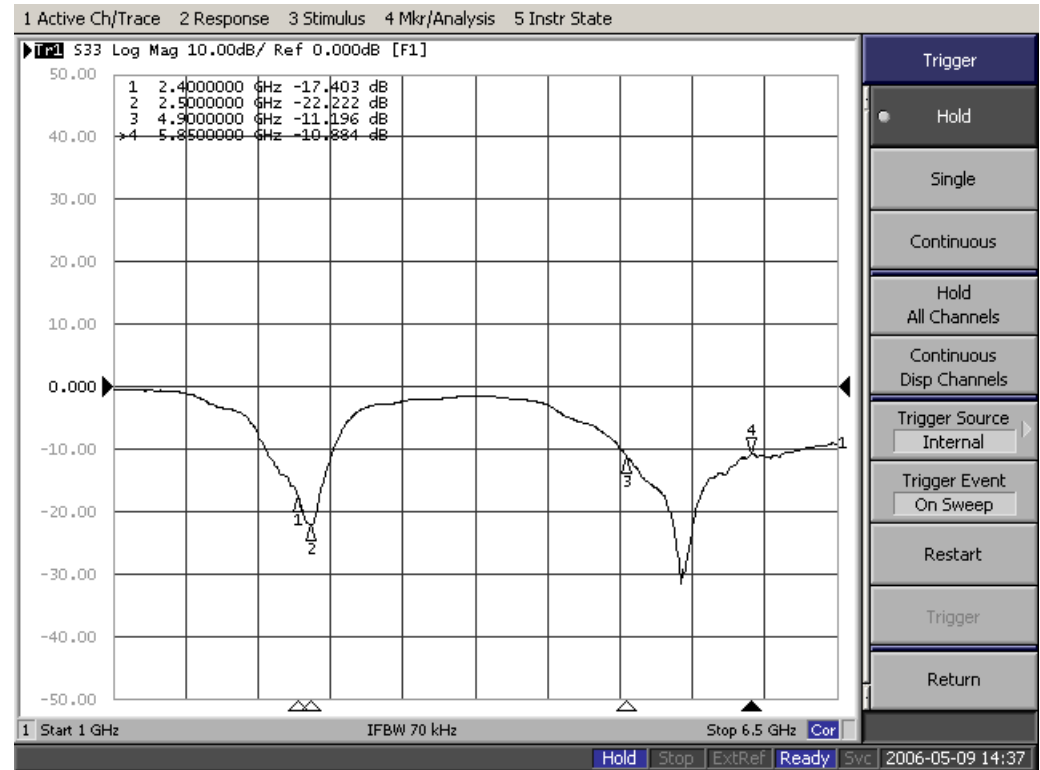

# TYPICAL FREQUENCY RESPONSE FOR DIFFERENT ANTENNA INSTALLATION – SMALL CARD (HORIZONTAL)

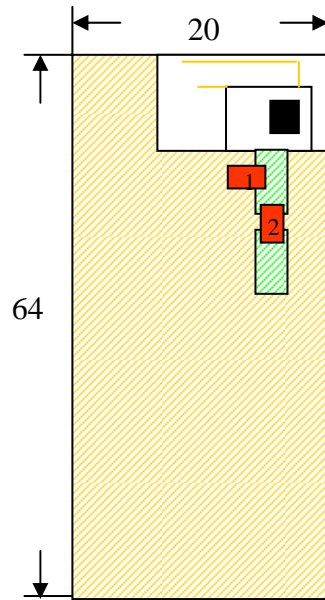

 50 ohm Feed Line  
 Matching Component

- 1 → 2.2 nH inductor shunt to ground
- 2 → 0 ohm bypass resistor

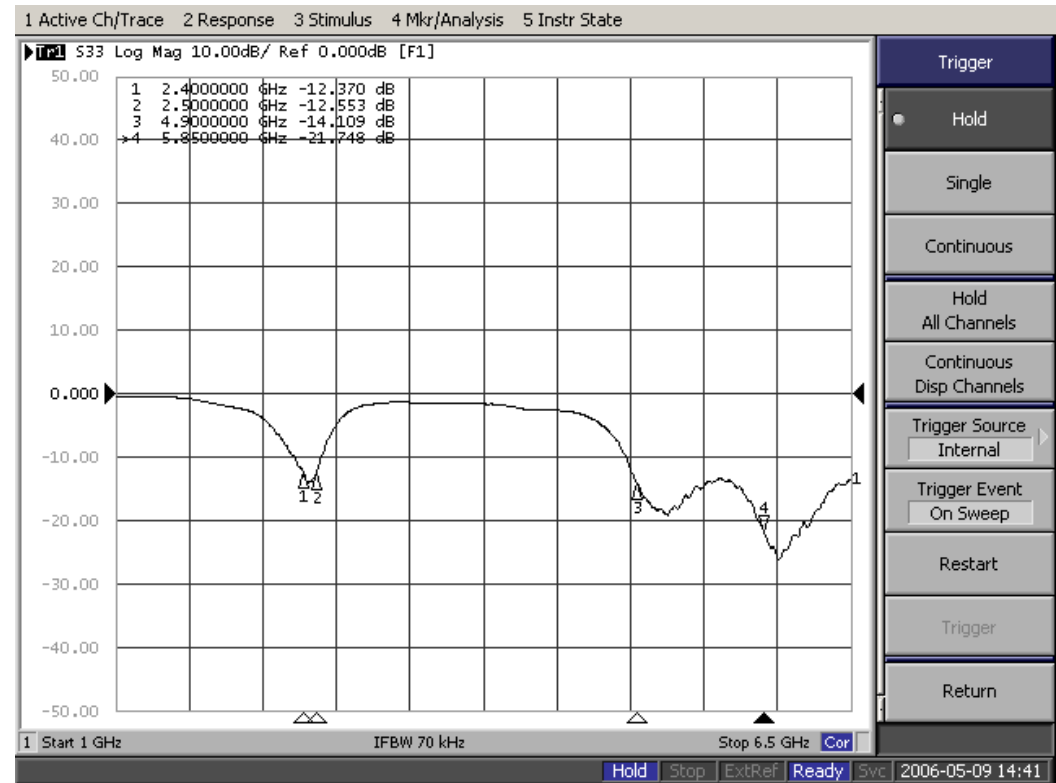

# TYPICAL FREQUENCY RESPONSE FOR DIFFERENT ANTENNA INSTALLATION – LARGER CARD (VERTICAL)

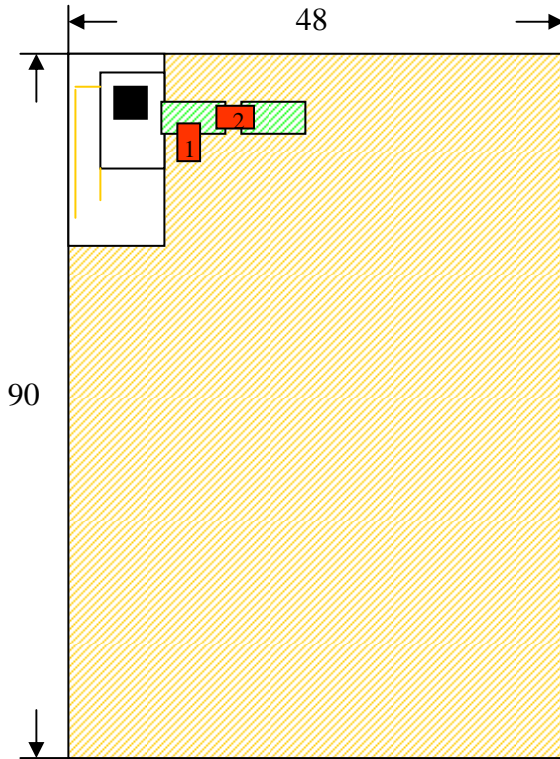

 50 ohm Feed Line

 Matching Component

1 → 3.3 nH inductor shunt to ground

2 → 0 ohm bypass resistor

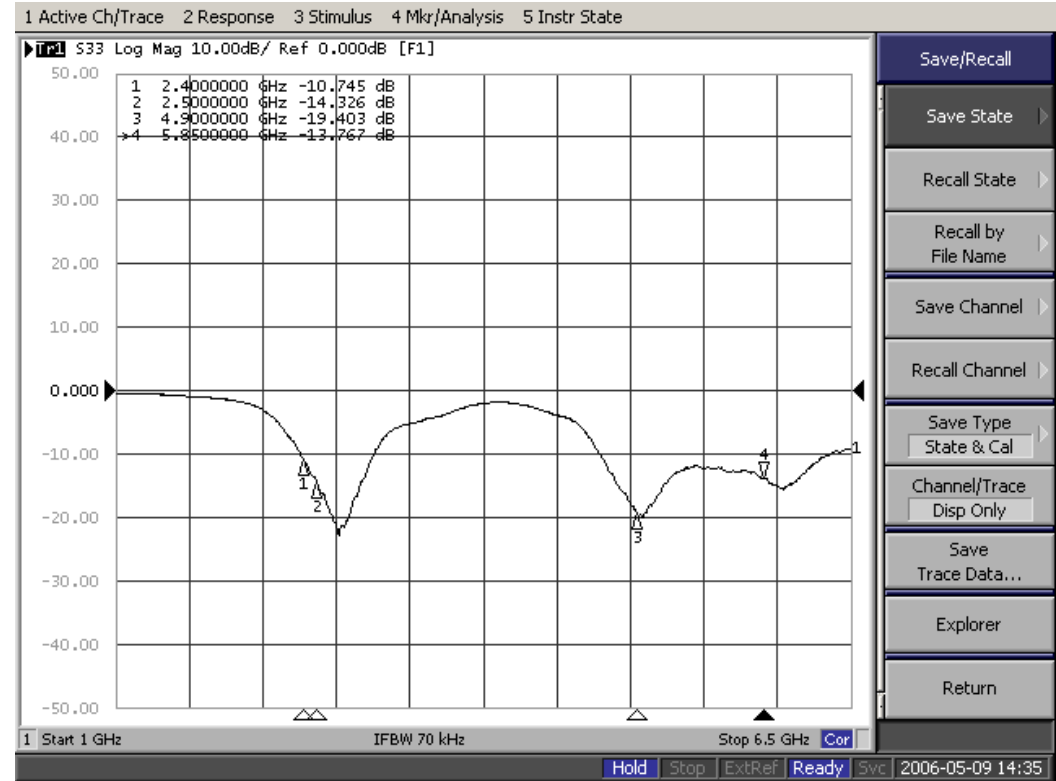

# TYPICAL FREQUENCY RESPONSE FOR DIFFERENT ANTENNA INSTALLATION – LARGER CARD (HORIZONTAL)

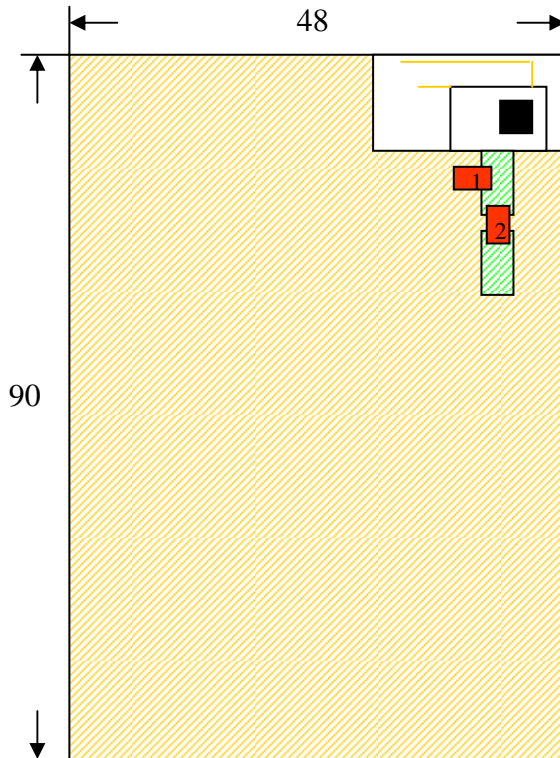

 50 ohm Feed Line

 Matching Component

1 → 2.2 nH inductor shunt to ground

2 → 0 ohm bypass resistor

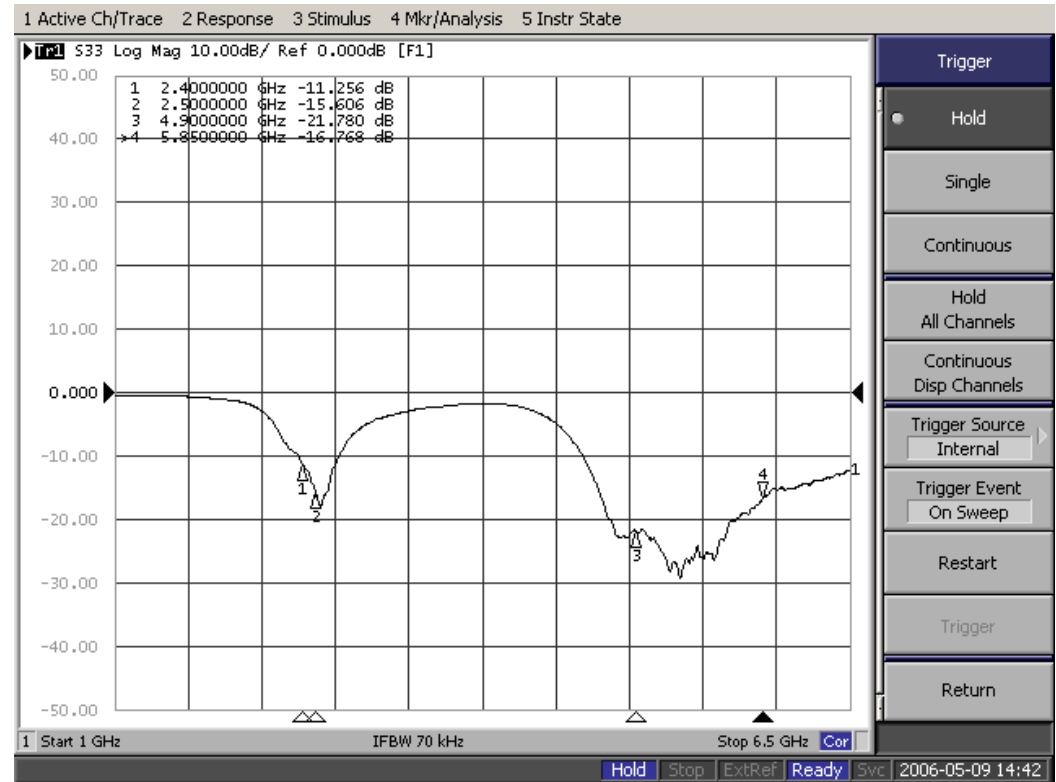

# TUNING GUIDELINE

# ANTENNA MATCHING GUIDELINE

- I. Optimize the lengths of tuning traces for lower band first, then the higher band.**
- II. For lower band tuning only (with minimum influence at higher band)  
=> choosing series capacitor and shunt inductor**
- III. For higher-band tuning only (with minimum influence at lower band)  
=> choosing series inductor and shunt capacitor**
- IV. Most encountered cases  
=> please refer to the attached example**

# FREQUENCY TUNING FOR LOWER BAND

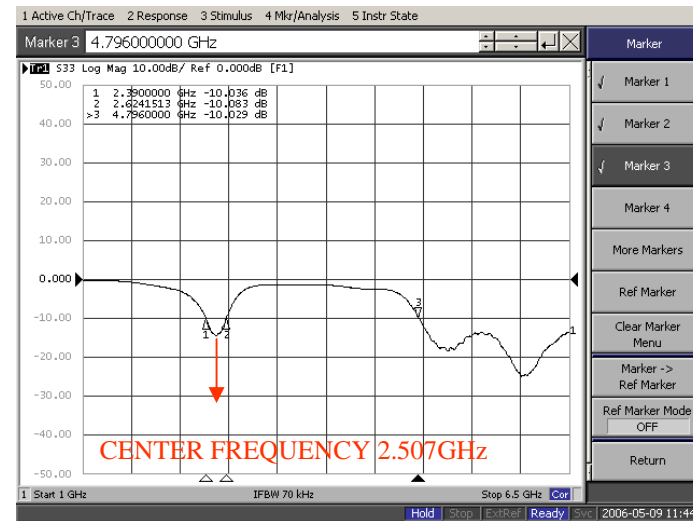
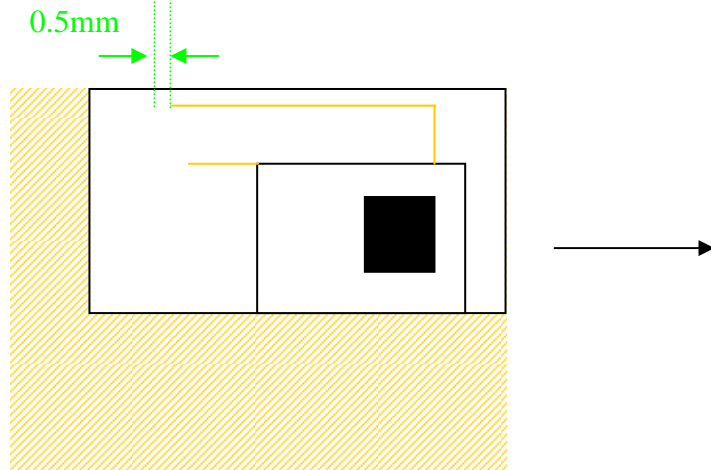
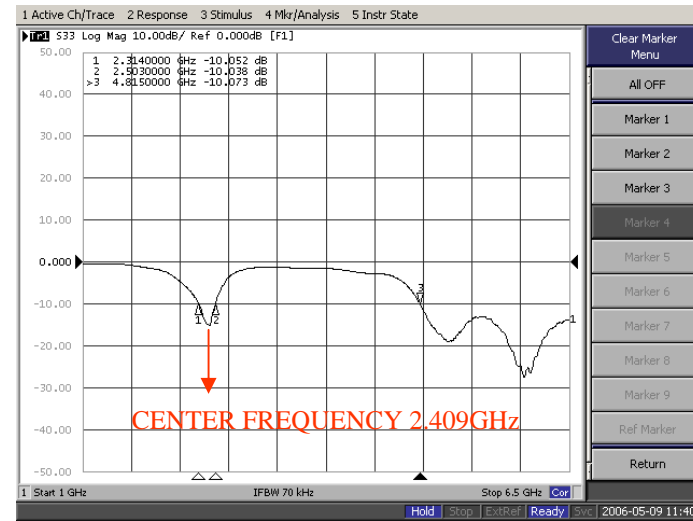
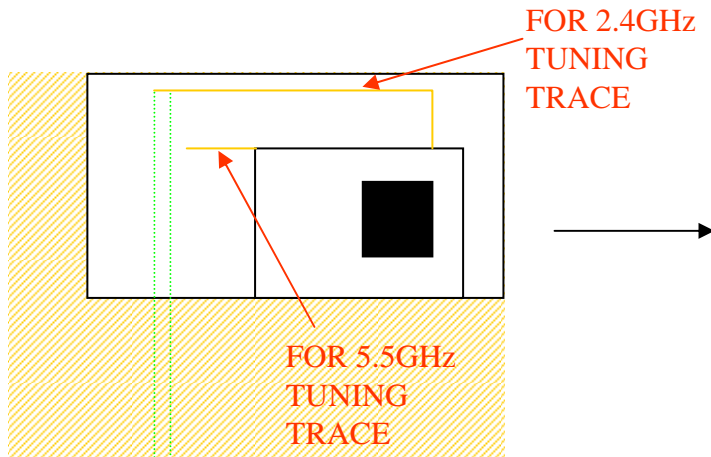

# FREQUENCY TUNING FOR HIGHER BAND

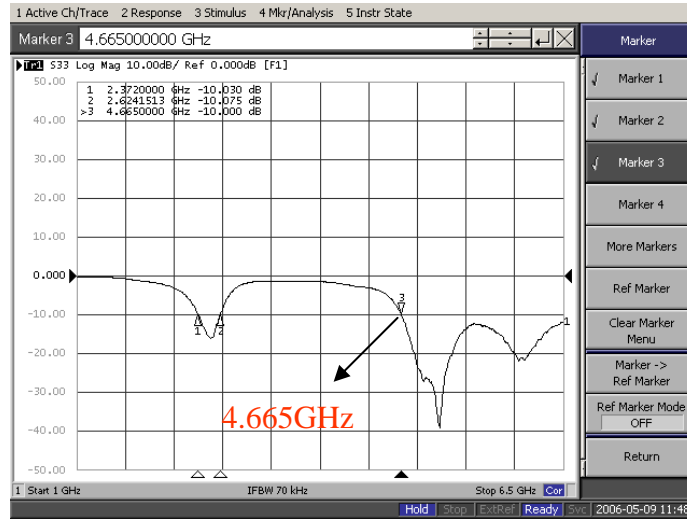
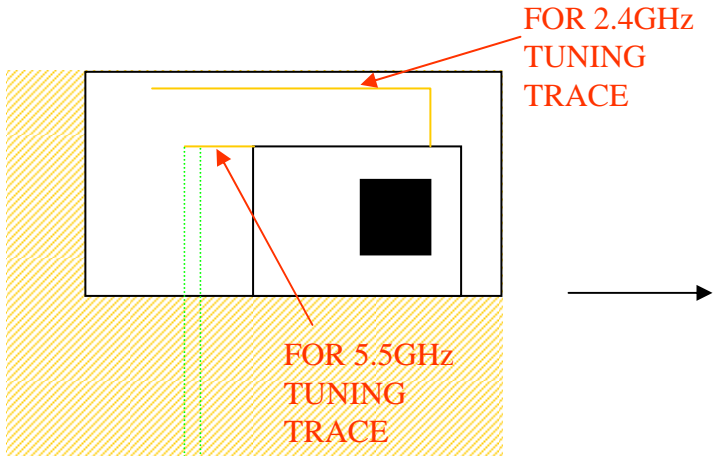

0.5mm

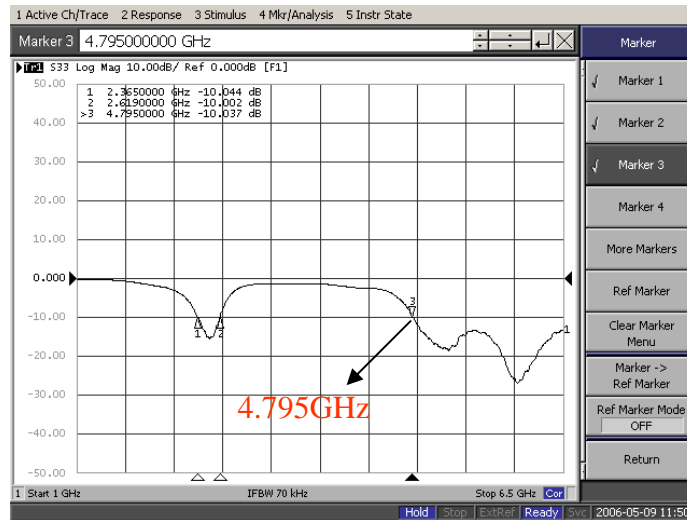
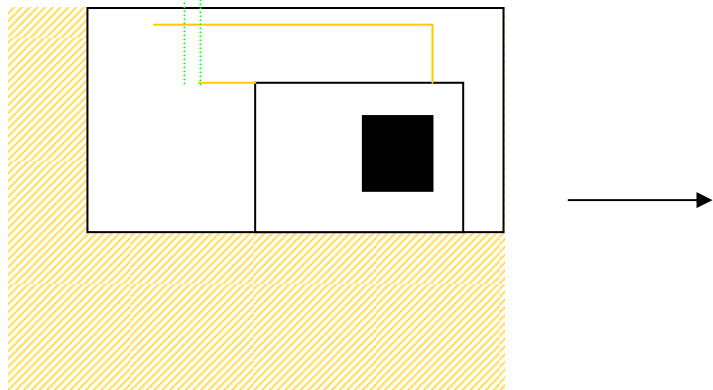

# MOST ENCOUNTERED CASE

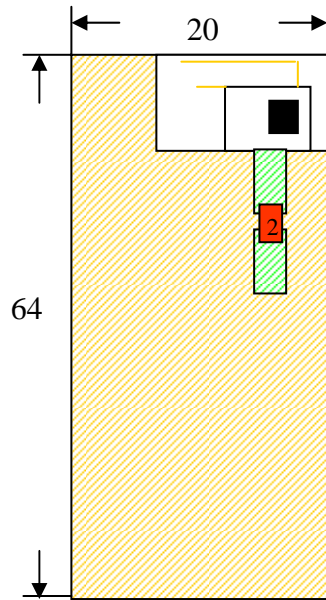

 50 ohm Feed Line  
 Matching Component

2 → 0 ohm bypass resistor

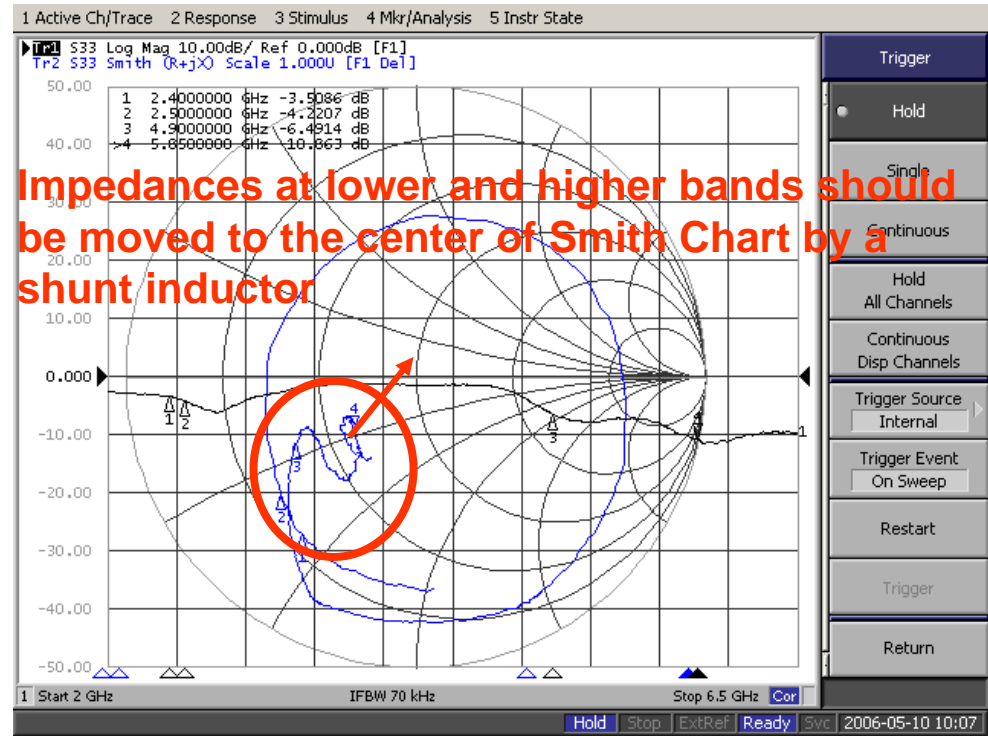

Impedances at lower and higher bands should be moved to the center of Smith Chart by a shunt inductor

❖ after tune the trace of 2.4GHz & 5.5GHz

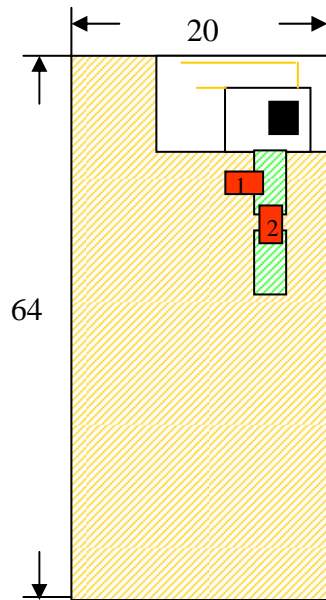

 50 ohm Feed Line  
 Matching Component

- 1 → 2.2 nH inductor shunt to ground
- 2 → 0 ohm bypass resistor

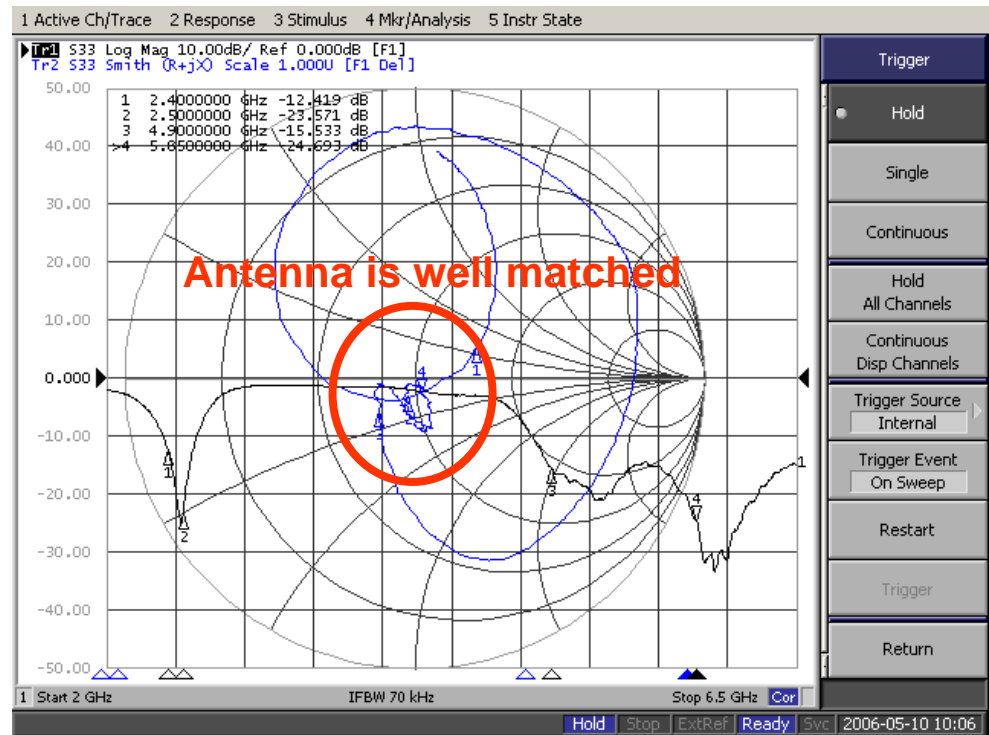

❖ after matching by shunt inductance