

SCOPE :

This specification applies to the Pb Free high current type SMD inductors for
MSCDRI-127TH0-SERIES

PRODUCT IDENTIFICATION

MSCDRI - 127T H0 - 100 M

① ② ③ ④ ⑤

- ① Product Code
- ② Dimensions Code
- ③ AEC-Q200 Code
- ④ Inductance Code
- ⑤ Tolerance Code

(1) SHAPES AND DIMENSIONS

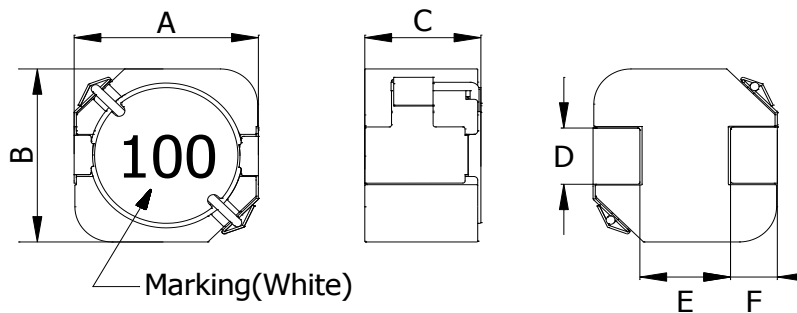

A:	12.5 ± 0.4	mm
B:	12.3 ± 0.4	mm
C:	8.5 Max.	mm
D:	4.0 Typ.	mm
E:	6.3 Typ.	mm
F:	3.15 Typ.	mm

(2) ELECTRICAL SPECIFICATIONS

SEE TABLE 1

TEST INSTRUMENTS

- L : HP 4284A PRECISION LCR METER (or equivalent)
- RDC : CHROMA MODEL 16502 MILLIOHMMETER (or equivalent)

(3) CHARACTERISTICS

(3)-1 Operate temperature range -40°C ~ +155°C

(Including self temp. rise)



MAG.LAYERS

TABLE 1

MAGLAYERS PT/NO.	Inductance L(μ H)	Percent Tolerance	Test Frequency	Resistance RDC(Ω) Max.	Rated DC Current		Marking
					Isat(A)	Irms(A)	
MSCDRI-127TH0-100□	10	M,N	100kHz/0.25V	20m	6.40	6.00	100
MSCDRI-127TH0-150□	15	M,N	100kHz/0.25V	34m	5.80	5.00	150
MSCDRI-127TH0-220□	22	M,N	100kHz/0.25V	37m	4.30	4.40	220
MSCDRI-127TH0-330□	33	M,N	100kHz/0.25V	68m	3.60	3.50	330
MSCDRI-127TH0-470□	47	M,N	100kHz/0.25V	82m	3.10	3.10	470
MSCDRI-127TH0-101□	100	M,N	100kHz/0.26V	0.133	2.10	2.50	101
MSCDRI-127TH0-151□	150	M,N	100kHz/0.26V	0.220	1.80	2.00	151
MSCDRI-127TH0-221□	220	M,N	100kHz/0.27V	0.330	1.50	1.50	221
MSCDRI-127TH0-331□	330	M,N	100kHz/0.27V	0.533	1.20	1.15	331
MSCDRI-127TH0-471□	470	M,N	100kHz/0.28V	0.755	1.00	1.00	471

※ □ specify the inductance tolerance, M(\pm 20%), N(\pm 30%)

※ Isat : Based on inductance change (Δ L/Lo : drop 30% Max.) @ambient temperature 25°C

Irms : Based on temperature rise (Δ T : 40°C Typ.)

Rated DC Current : The less value which is Isat or Irms.

(4) RELIABILITY TEST METHOD ELECTRICAL

TEST ITEM	SPECIFICATION	TEST DETAILS
Insulation resistance	There shall be no other damage or problems.	DC 100V voltage shall be applied across this sample of top surface and the terminal. The insulation resistance shall be more than $1 \times 10^8 \Omega$.
Dielectric withstand voltage	There shall be no other damage or problems.	AC 100V voltage shall be applied for 1 minute across the top surface and the terminal of this sample
Temperature characteristics	$\Delta L/L20^\circ C \leq \pm 10\%$ 0~2000 ppm/ $^\circ C$	The test shall be performed after the sample has stabilized in an ambient temperature of -20 to +85 $^\circ C$, and the value calculated based on the value applicable in a normal temperature and normal humidity shall be $\Delta L/L20^\circ C \leq \pm 10\%$.

MECHANICAL

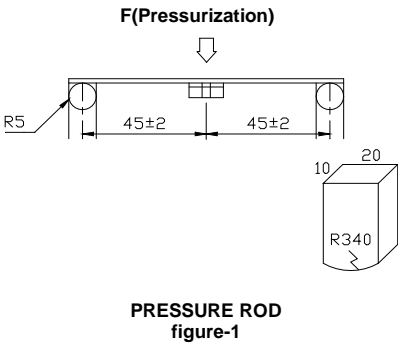
TEST ITEM	SPECIFICATION	TEST DETAILS
Substrate bending	$\Delta L/L_0 \leq \pm 5\%$ There shall be no mechanical damage or electrical damage.	The sample shall be soldered onto the printed circuit board in figure 1 and a load applied until the figure in the arrow direction is made approximately 3mm. 60 sec minimum holding time. PCB dimension shall be page 7/9  <p style="text-align: center;">PRESSURE ROD figure-1</p>
Flammability	There shall be no other damage or problems.	Burning stops within 10 seconds on a vertical specimen; drips of particles allowed as long as they are not inflamed.
Terminal Strength	There shall be no other damage or problems.	With the component mounted on a PCB obtained from the Supplier with the device to be tested, apply a 17.7 N (1.8 Kg) force to the side of a device being tested. This force shall be applied for 60 +1 seconds.
Mechanical Shock	$\Delta L/L_0 \leq \pm 5\%$ There shall be no mechanical damage.	100g's/6ms/Half-sine/12.3ft/sec

MECHANICAL

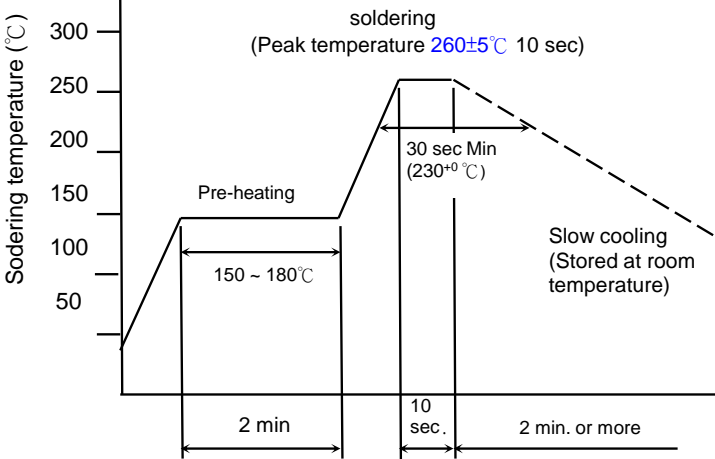
TEST ITEM	SPECIFICATION	
Vibration	$\Delta L/L_0 \leq \pm 5\%$ There shall be no mechanical damage.	5g's for 20 minutes, 12 cycles each of 3 orientations. Test from 10-2000 Hz.
Solderability	New solder More than 90%	Flux (rosin, isopropyl alcohol{JIS-K-1522}) shall be coated over the whole of the sample before hard, the sample shall then be preheated for about 2 minutes in a temperature of 130~150°C and after it has been immersed to a depth 0.5mm below for 3±1 seconds fully in molten solder M705 with a temperature of 245±5°C. More than 90% of the electrode sections shall be covered with new solder smoothly when the sample is taken out of the solder bath.
Resistance to Soldering heat (reflow soldering)	There shall be no damage or problems.	<p style="text-align: center;">Temperature profile of reflow soldering</p>  <p style="text-align: center;">Soldering temperature (°C)</p> <p style="text-align: center;">300 250 200 150 100 50</p> <p style="text-align: center;">Pre-heating 150 ~ 180°C 2 min</p> <p style="text-align: center;">soldering (Peak temperature 260±5°C 10 sec)</p> <p style="text-align: center;">30 sec Min (230±0°C)</p> <p style="text-align: center;">10 sec.</p> <p style="text-align: center;">2 min. or more</p> <p style="text-align: center;">Slow cooling (Stored at room temperature)</p> <p>Solder temperature : 260 ±5°C Dip time: 10 ±1 seconds The chip shall not crack. More than 75% of the terminal electrode shall be covered with solder.</p>

ENVIROMENT CHARACTERISTICS

TEST ITEM	SPECIFICATION	
High temperature storage	$\Delta L/Lo \leq \pm 5\%$ There shall be no mechanical damage.	1000hrs.at rated operating temperature (e.g. 155°C part can be stored for 1000hrs.@ 155°C.Same applies for 125°C and 105°C. Unpowered. Measurement at 24±4 hours after test conclusion.
Temperature Cycling	$\Delta L/Lo \leq \pm 5\%$ There shall be no other damage of problems	1000cycles (-40°C to +155°C).Note: If 105°C part or 125°C part the 1000cycles will be at that temperature. Measurement at 24±4hours after test conclusion. 30min maximum dwell time at each temperature extreme.1min. maximum transition time.
Operational Life	$\Delta L/Lo \leq \pm 5\%$ There shall be no mechanical damage.	1000hrs. @155°C. If 105°C or 125°C part will be Tested at that temperature. Measurement at 24±4 hours after test conclusion
Biased Humidity	$\Delta L/Lo \leq \pm 5\%$ There shall be no mechanical damage.	1000hours 85°C/85%RH. Unpowered.Measurement at 24±4hours after test conclusion.
Test conditions : The sample shall be reflow soldered onto the printed circuit board in every test.		

(5) LAND DIMENSION (Ref.)

PCB: GLASS EPOXY t=1.6mm

(5)-1 LAND PATTERN DIMENSIONS

(STANDARD PATTERN)

Unit:mm

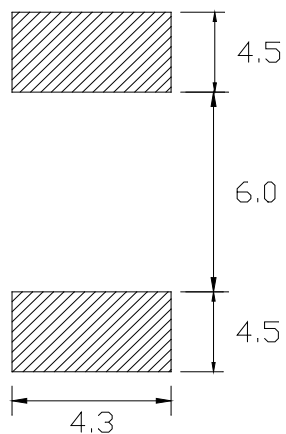

(5)-2 SUBSTRATE BENDING TEST BENDING TEST BOARD

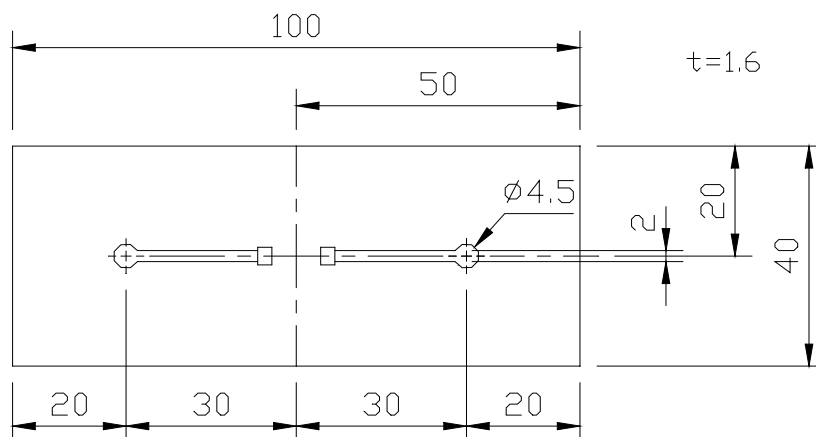

(6) PACKAGING

(6)-1 CARRIER TAPE DIMENSIONS (mm)

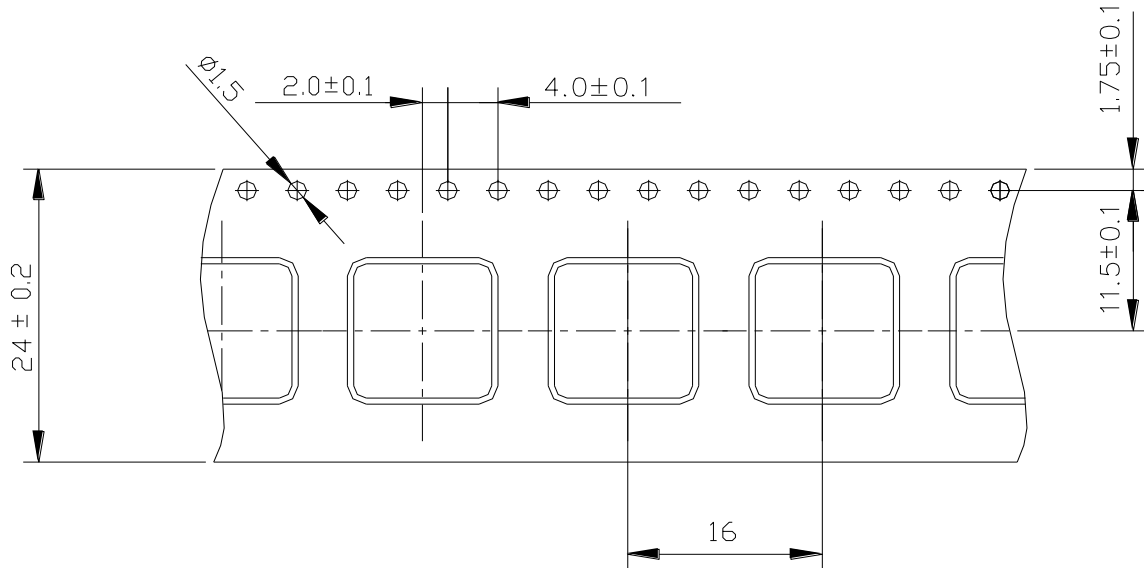

(6)-2 TAPING DIMENSIONS (mm)

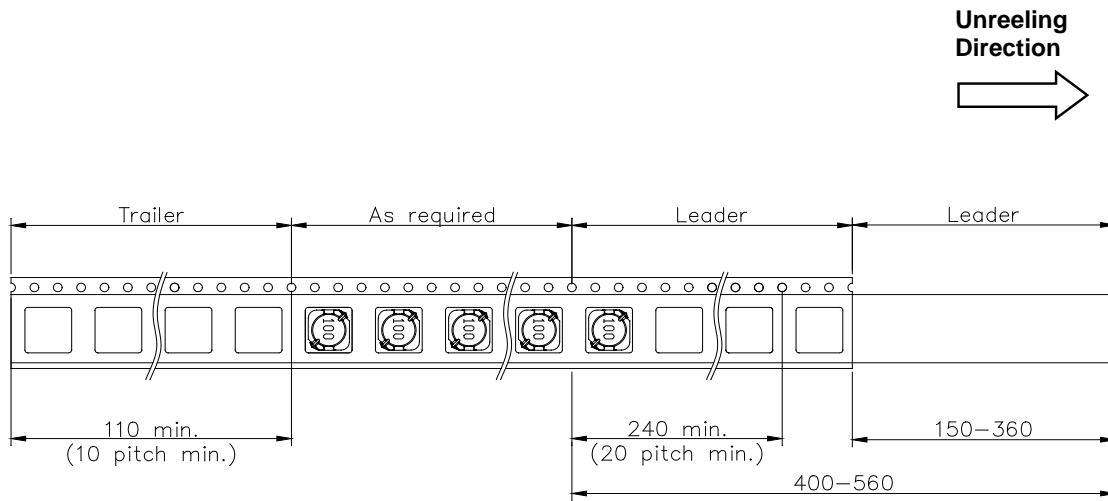

(6)-3 REEL DIMENSIONS (mm)

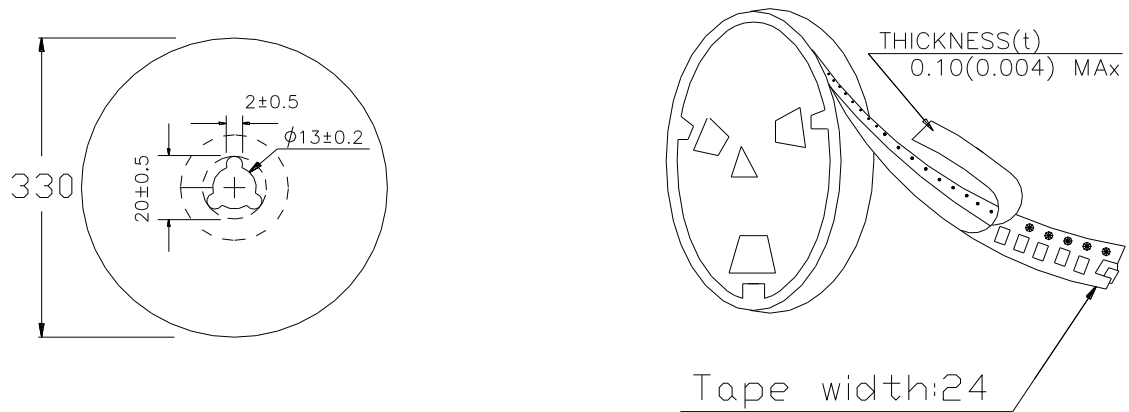

(6)-4 QUANTITY

400 pcs/Reel

The products are packaged so that no damage will be sustained.

Please note that the contents may change without any prior notice due to reasons such as upgrading.